



WRITEASSIST

Improving Writing Education Using GenAI

Capstone Section 8

Richard Mathews II, Emily McPherson, Sabreena Naser, Patrick Xu, Daphne Lin

Meet Our Team



Richard Mathews II
Project Manager/
Data Scientist



Emily McPherson
App Developer



Daphne Lin
Data Scientist



Sabreena Naser
Data Scientist



Patrick Xu
Data Scientist

Problem

In grades 6-12 writing education, **overwhelming teacher workloads** result in dissatisfaction and high turnover rates, leading to the **lack of individualized feedback** for students, which hinders their writing development.

77% English middle and high school teachers report feeling stressed or overwhelmed.



Our Solution

WriteAssist: A classroom aligned AI teacher assistant that **automates personalized feedback** generation and offers 1:1 student counseling, enhancing both teacher efficiency and student writing proficiency

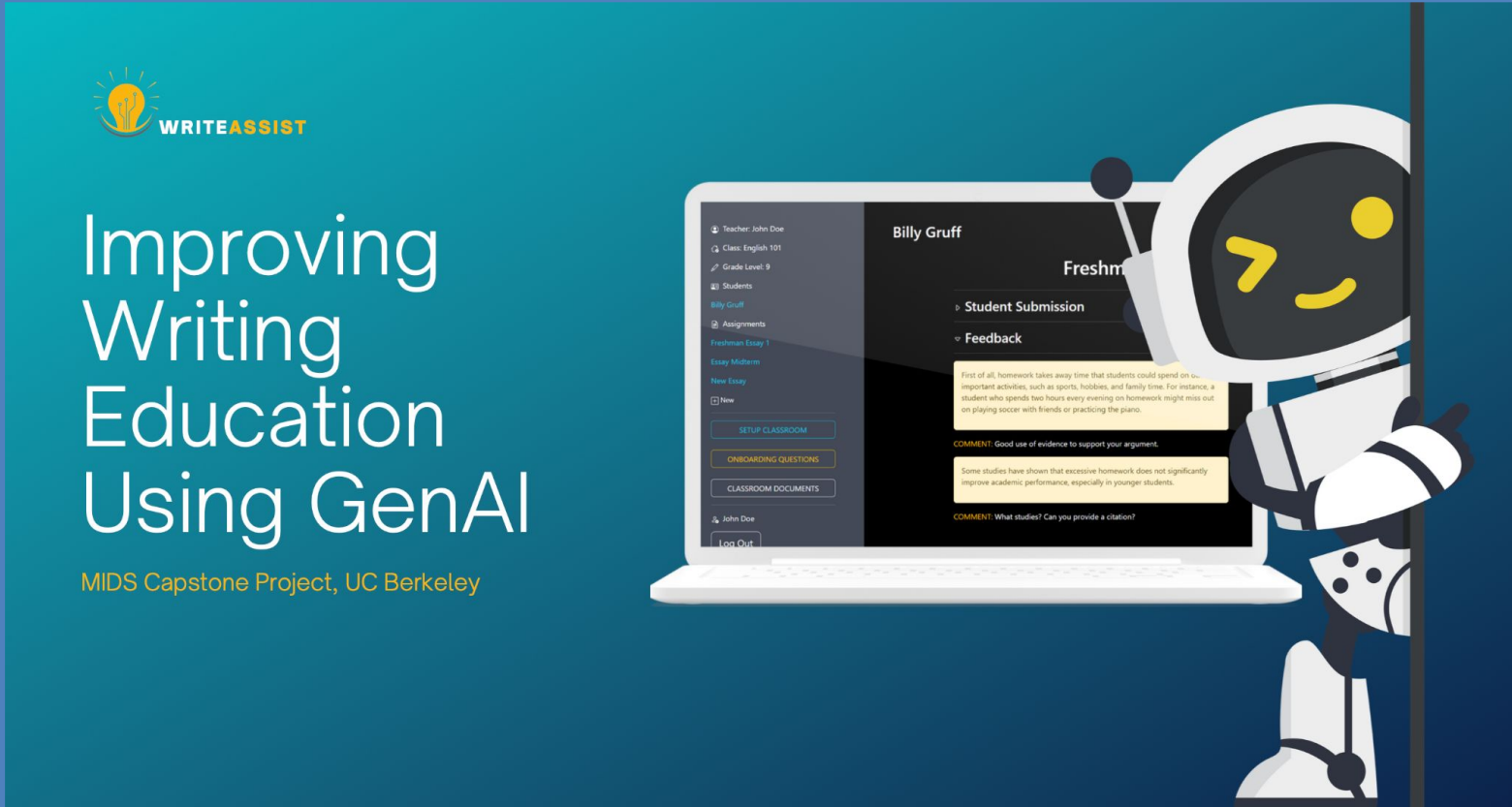

 WRITEASSIST

Improving Writing Education Using GenAI

MIDS Capstone Project, UC Berkeley

Teacher: John Doe
Class: English 101
Grade Level: 9
Students
Billy Gruff
Assignments
Freshman Essay 1
Essay Midterm
New Essay
New

SETUP CLASSROOM
ONBOARDING QUESTIONS
CLASSROOM DOCUMENTS

John Doe
Log Out

Billy Gruff
Freshman Essay 1
Student Submission
Feedback

First of all, homework takes away time that students could spend on important activities, such as sports, hobbies, and family time. For instance, a student who spends two hours every evening on homework might miss out on playing soccer with friends or practicing the piano.

COMMENT: Good use of evidence to support your argument.

Some studies have shown that excessive homework does not significantly improve academic performance, especially in younger students.

COMMENT: What studies? Can you provide a citation?

High Market Opportunity



Over 4 million teachers
in the U.S.



Over 49 million
students in U.S. public
schools

- The U.S. education technology market was valued at around **\$80 billion**
- Expected to grow at a compound annual **growth rate of >11%**
- Assuming WriteAssist is adopted by 10% of schools in the U.S., the potential reach is around **4.9 million students** and **400,000 teachers**

Adopting a User-Driven Focus



Research and User Interviews

We interviewed 5 teachers and 11 students

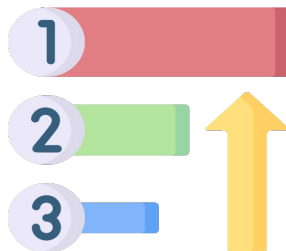

Setting Priorities

1. Personalizing the AI to the teacher's goals, style, and curriculum.
2. Students get quality 1:1 feedback on their writing.
3. Teachers write feedback faster.

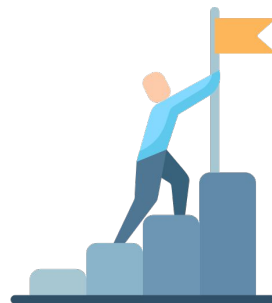

Objective

Automate as much of the student-teacher feedback loop without sacrificing uniqueness of the teacher/classroom.

MVP Key Features



Onboarding

Teacher provides information such as goals, preferences, curriculum, rubrics, resources, and previous feedback samples.



Feedback Generation

Teacher can provide feedback to essays, or generate feedback suggestions using AI.



Student/AI Conferencing

Student interacts with their essay feedback via teacher AI chat conversation.

Demo: 7th Grade Persuasive Essay



Mr. Williams



Billy

User Feedback

"I really like the concept of the app - especially how easy it is for both the teacher and the student. It provides quick and effective feedback for the student. The feedback is also clear and appropriate based on the students grade level! I also like the AI teacher assistant tool a lot for students to gain a better understanding!"

Amaya Hodges, 8th Grade English Teacher

"The WriteAssist site showcases a promising tool for improving writing efficiency and quality!"

Sonia Khan, High School Senior

Map Diagram

1. Training Data

ASAP++ Dataset

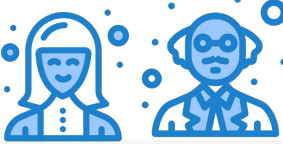
Synthetic Teacher Personas



2. ML Pipeline

Create Proprietary Dataset



End-to-End GenAI Experimentation

Evaluation

3. MVP - live demo

Teacher Onboarding and Inputs

User-input

Student Essays

Real Data

Teacher and Feedback Generation Models

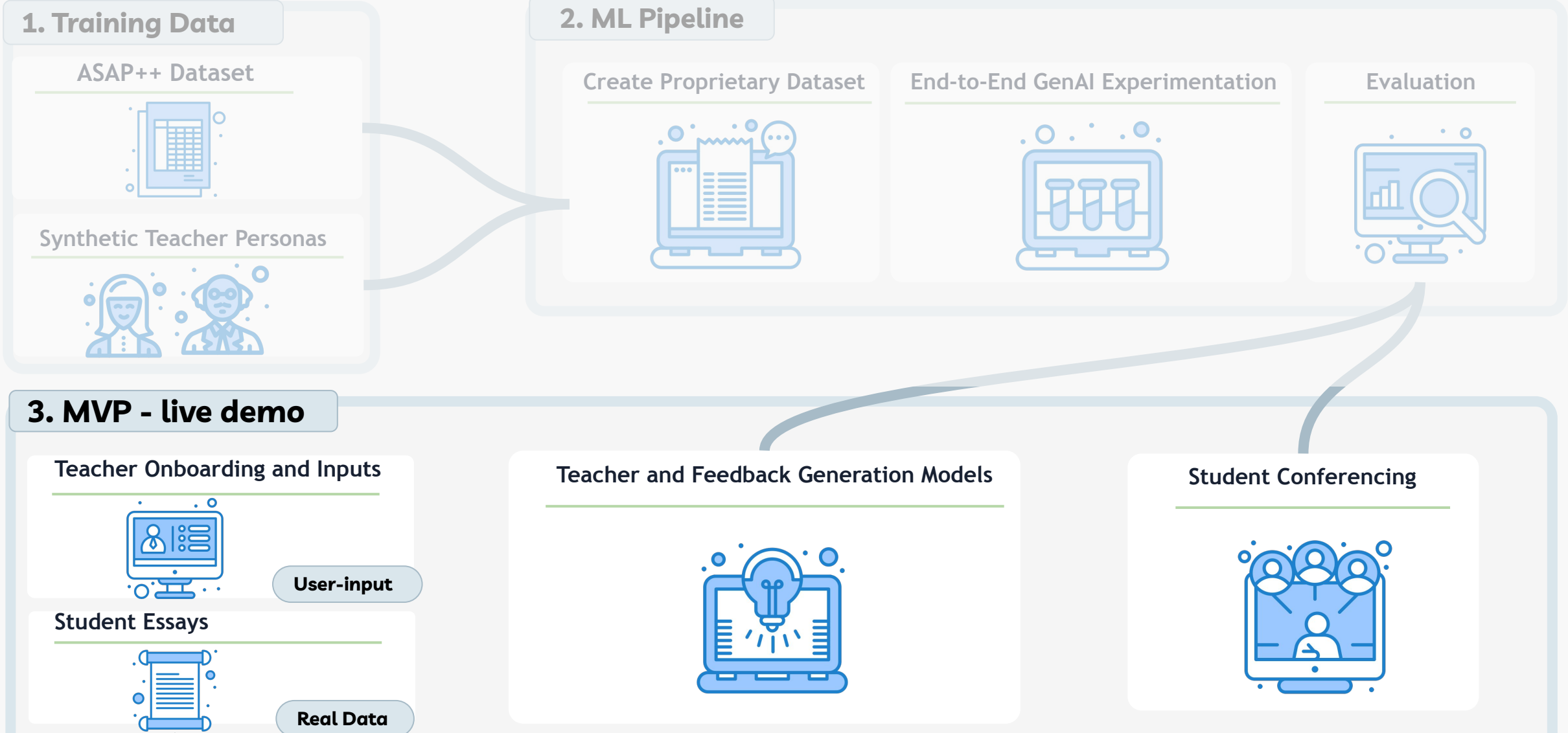
Student Conferencing

Map Diagram



Map Diagram

1. Training Data

ASAP++ Dataset



Synthetic Teacher Personas



2. ML Pipeline

Create Proprietary Dataset



End-to-End GenAI Experimentation



Evaluation



3. MVP - live demo

Teacher Onboarding and Inputs



User-input

Student Essays



Real Data

Teacher and Feedback Generation Models



Student Conferencing



Proprietary Dataset

ASAP++ DATASET

input

Prompts



“Write a letter to your local newspaper in which you state your opinion on the effects computers have on people. Persuade the readers to agree with you.”

Rubrics



Evaluate Ideas & Content. A score 6 denotes that the writing is exceptionally clear, focused, and interesting. [...] Main ideas stand out and are developed by strong support and rich details suitable to audience and purpose. [...]

Essays



“[...]Before my famiy had a computer complete dedicated to papers files that your so important & that we could not lose. When up got picture, typed up paper, saved our was empty! I hope that this letter has proves to you computers effect on our society. [...]

Scores



EssayID	Content	Org	Word Choice	Fluency	Conventions
919	3	4	3	3	3



input

Synthetic Teacher Personas



Synthetic Teacher 1

- Prioritizes grammatical accuracy and adherence to language conventions.
- Focuses on the clarity of the thesis
- Looks for strong development and support of arguments
- Looks for a conclusion that effectively summarizes the thesis.

GPT-4o

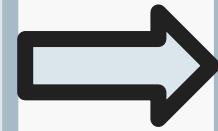

output

Proprietary Dataset



“The essay you provided has a clear understanding of the main ideas regarding the positive effects of computers on society. However, it struggles significantly with clarity, grammatical accuracy, and logical organization. [...]To improve, the essay needs a thorough revision to enhance grammatical precision, logical organization, and clarity of expression.”

Map Diagram



1. Training Data

ASAP++ Dataset



Synthetic Teacher Personas



2. ML Pipeline

Create Proprietary Dataset



End-to-End GenAI Experimentation



Evaluation



3. MVP - live demo

Teacher Onboarding and Inputs



User-input

Student Essays



Real Data

Teacher and Feedback Generation Models



Student Conferencing



Inference System

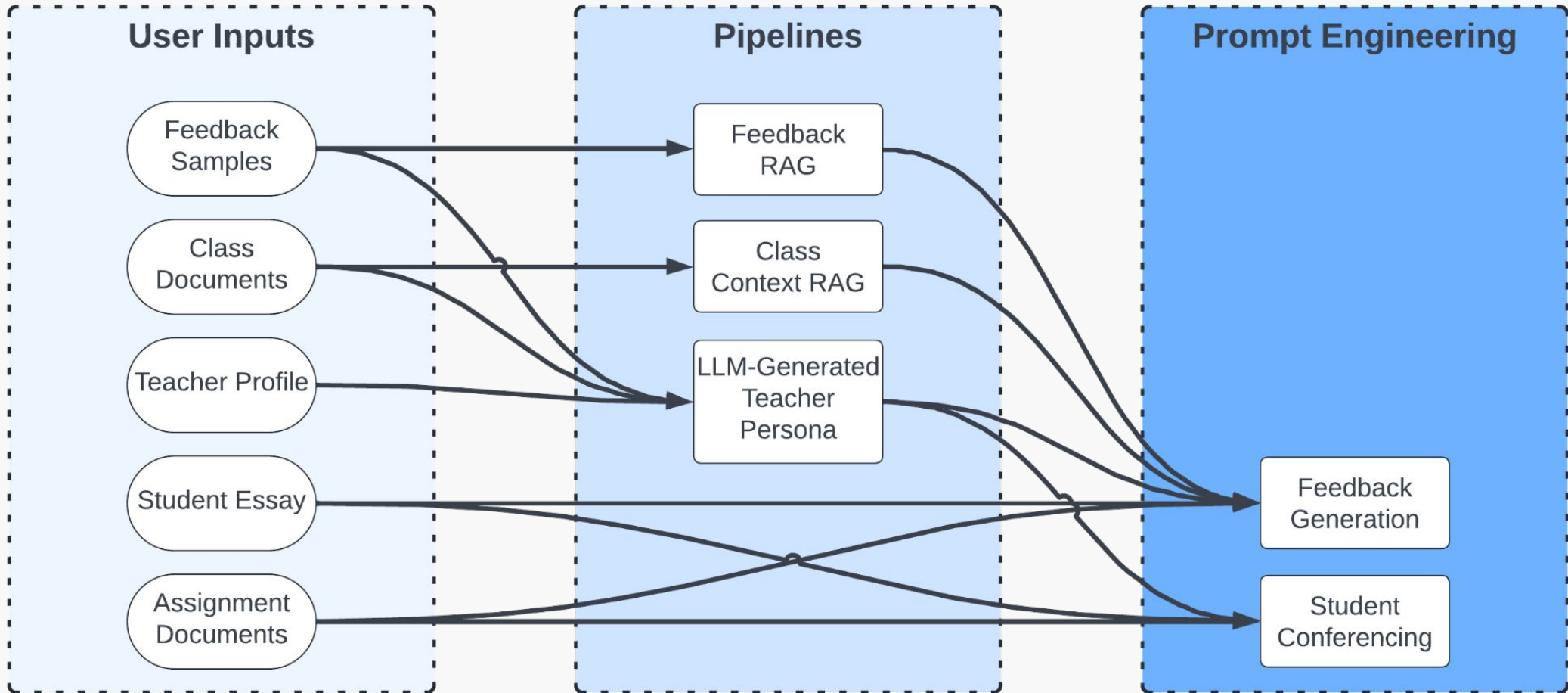

GenAIOps System

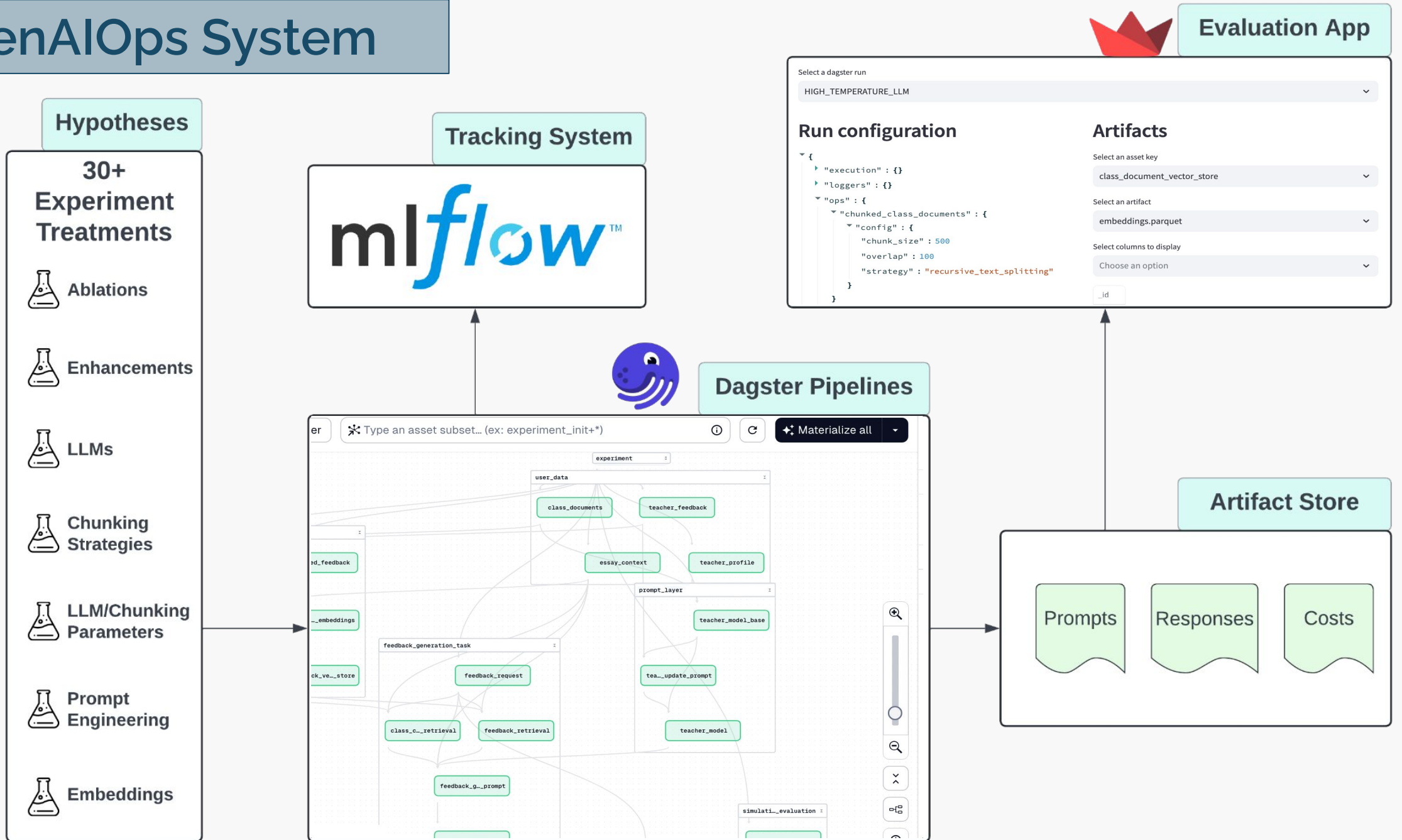

Map Diagram



1. Training Data

ASAP++ Dataset



Synthetic Teacher Personas



Create Proprietary Dataset



End-to-End GenAI Experimentation



2. ML Pipeline

Evaluation



3. MVP - live demo

Teacher Onboarding and Inputs

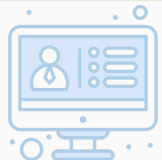

User-input

Student Essays



Real Data

Teacher and Feedback Generation Models



Student Conferencing



Evaluation

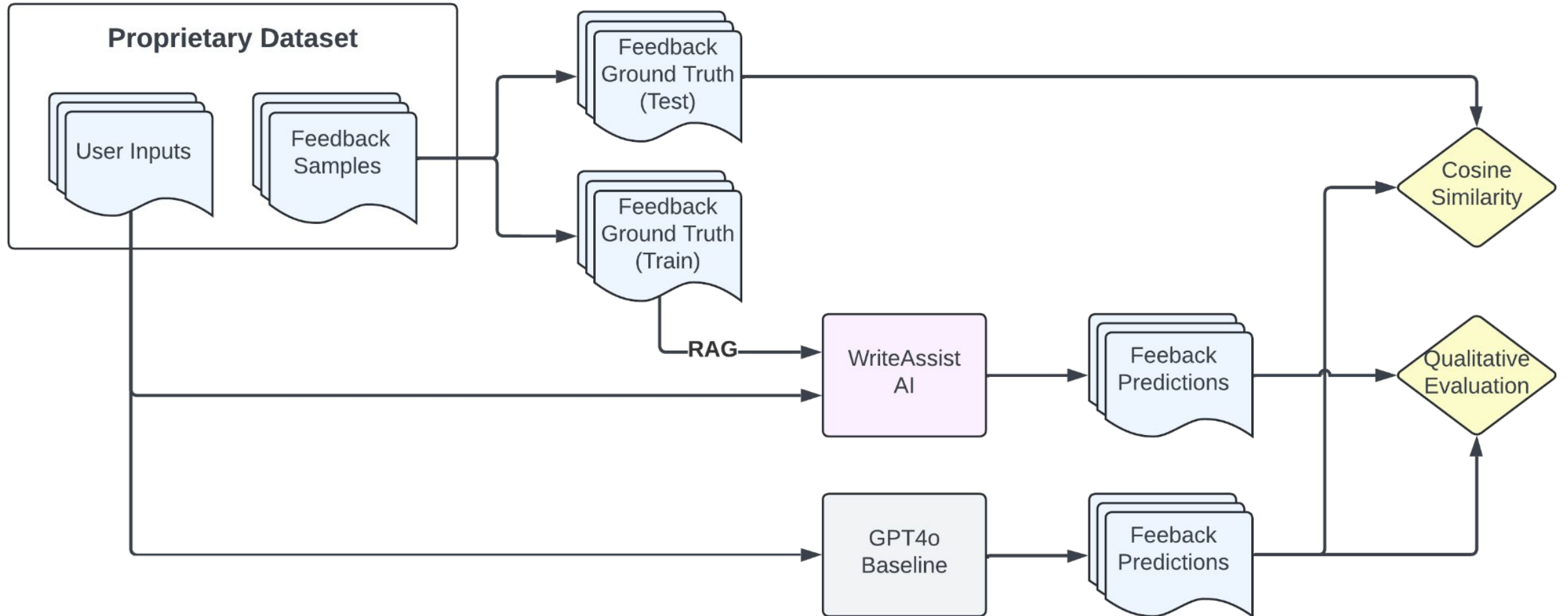

Dataset Summary

essay_id	essay_set	essay	rater1_domain1	rater2_domain1	domain1_score	
3499	4694	2	Do you think that certain materials should be ...	4.0	3.0	4.0
7167	11913	5	In the memoir, "Narciso Rodriguez from Home: t...	2.0	2.0	2.0
5976	9532	4	The Author concludes this story With the @CAPS...	1.0	1.0	1.0
5588	9143	4	The author wrote this paragraph at the end of ...	1.0	1.0	1.0
12314	20791	8	Laughter @MONTH1 be the best part of life. It...	20.0	18.0	38.0
1859	3054	2	Do you believe libraries should remove items s...	3.0	4.0	3.0
7058	10620	4	I think the Author ends this as the concluding...	2.0	1.0	2.0
11720	18979	7	A day that I was patient was, one day I was re...	8.0	10.0	18.0
4454	6851	3	The setting for the cyclist is a hard and dang...	2.0	1.0	2.0
11587	18834	7	Two week sago meandmy family went to siyflags,...	8.0	9.0	17.0

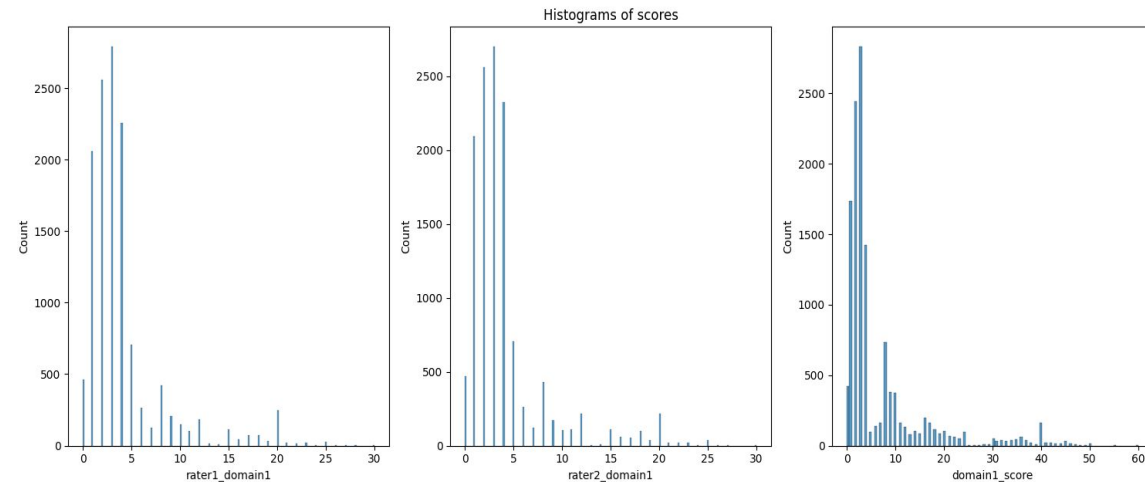

- Automated Student Assessment Prize (ASAP)
- 12977 student essays
- 8 prompts with rubrics
- Scores from 2 raters

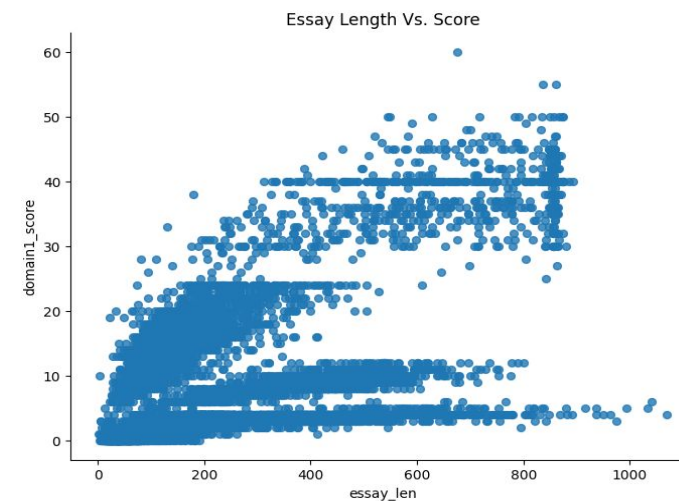
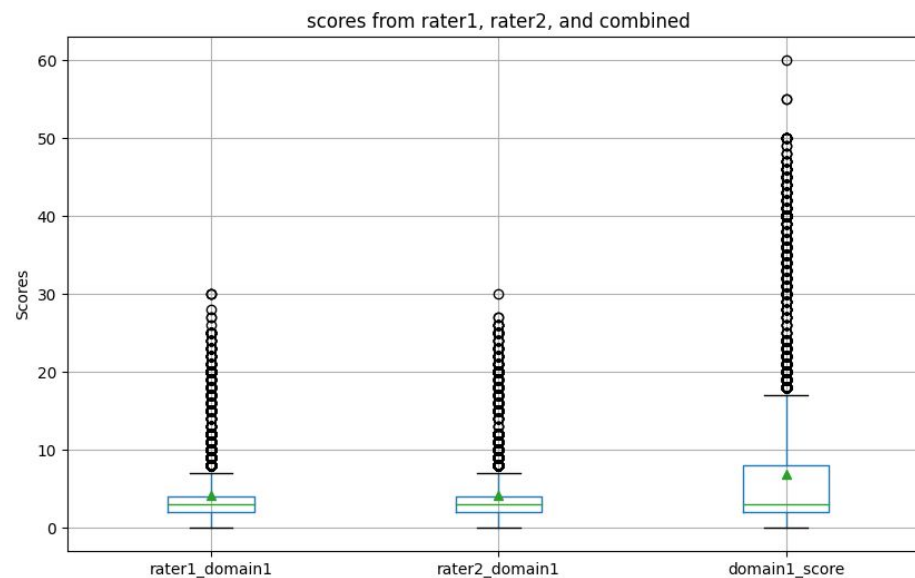
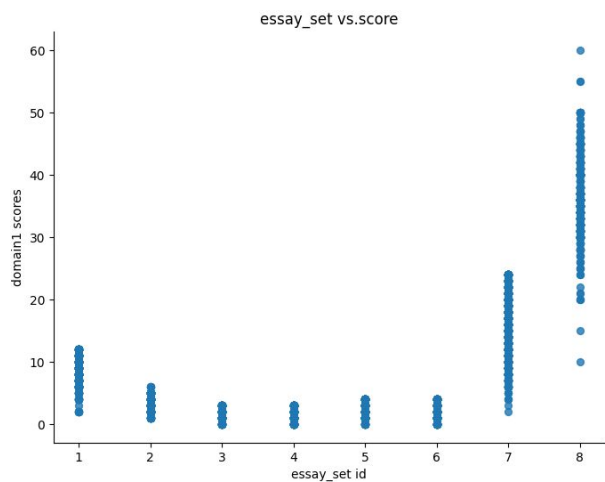

Experiment Results



Quantitative Results

(Feedback Generation)

- ✓ Few-shot learning
- ✓ Onboarding Q&A
- ✗ Bulleted lists
- ✗ Small chunks



Qualitative Results

(Feedback Generation, Student Conferencing)

- Evaluated top 3 (out of 30+) configurations
- Randomly sampled 5 per teacher
- Rated 1-5 on rubrics we developed based on user interviews

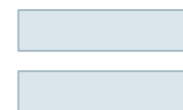

Final Configuration

- ✓ Feedback RAG
- ✓ GPT4-o
- ✓ Teacher persona injection
- ✗ Dynamic teacher personas

Recap: Three Innovations

Developed a personalized feedback system

Teacher AI models used for 1:1 student conferencing

Constructed an end-to-end GenAI Ops concept

Scalable and Low-Cost

1:1 Counseling Support

Machine Learning, MLOps, GenAI COMBINED

Future Work Roadmap

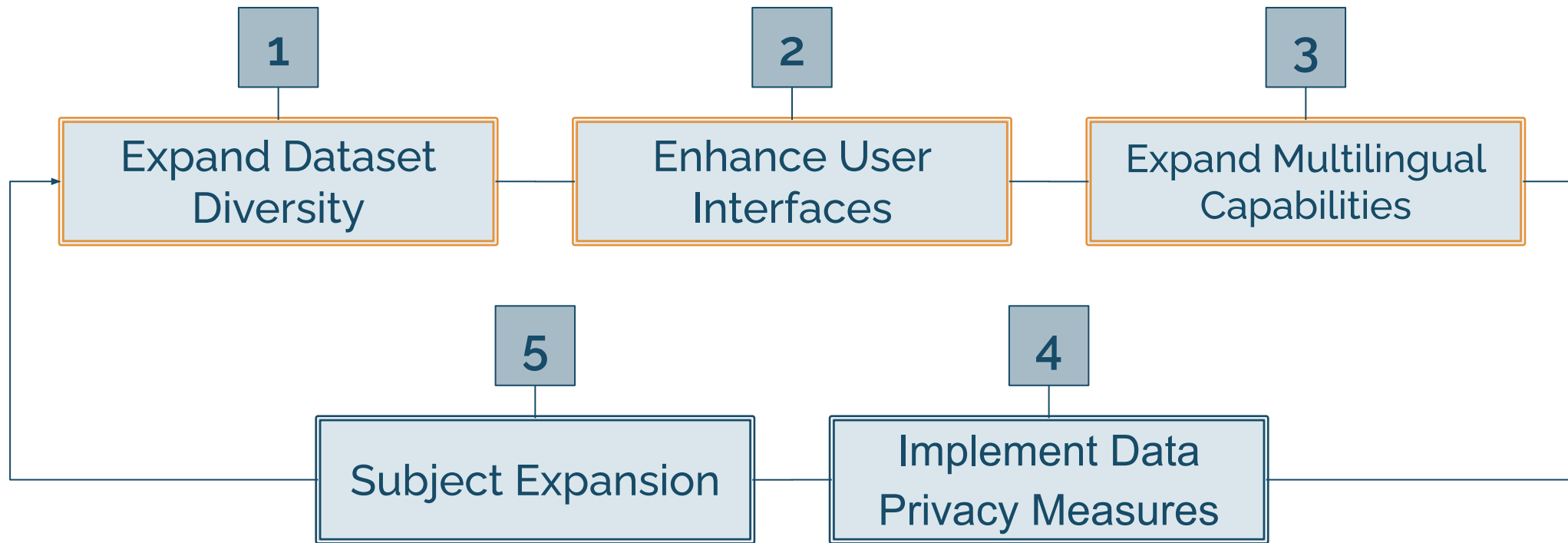

Project Mission

Reduce teacher burnout and improve student writing proficiency by equipping teachers with a classroom-aligned AI assistant that automates feedback generation and supports students with 1:1 counseling

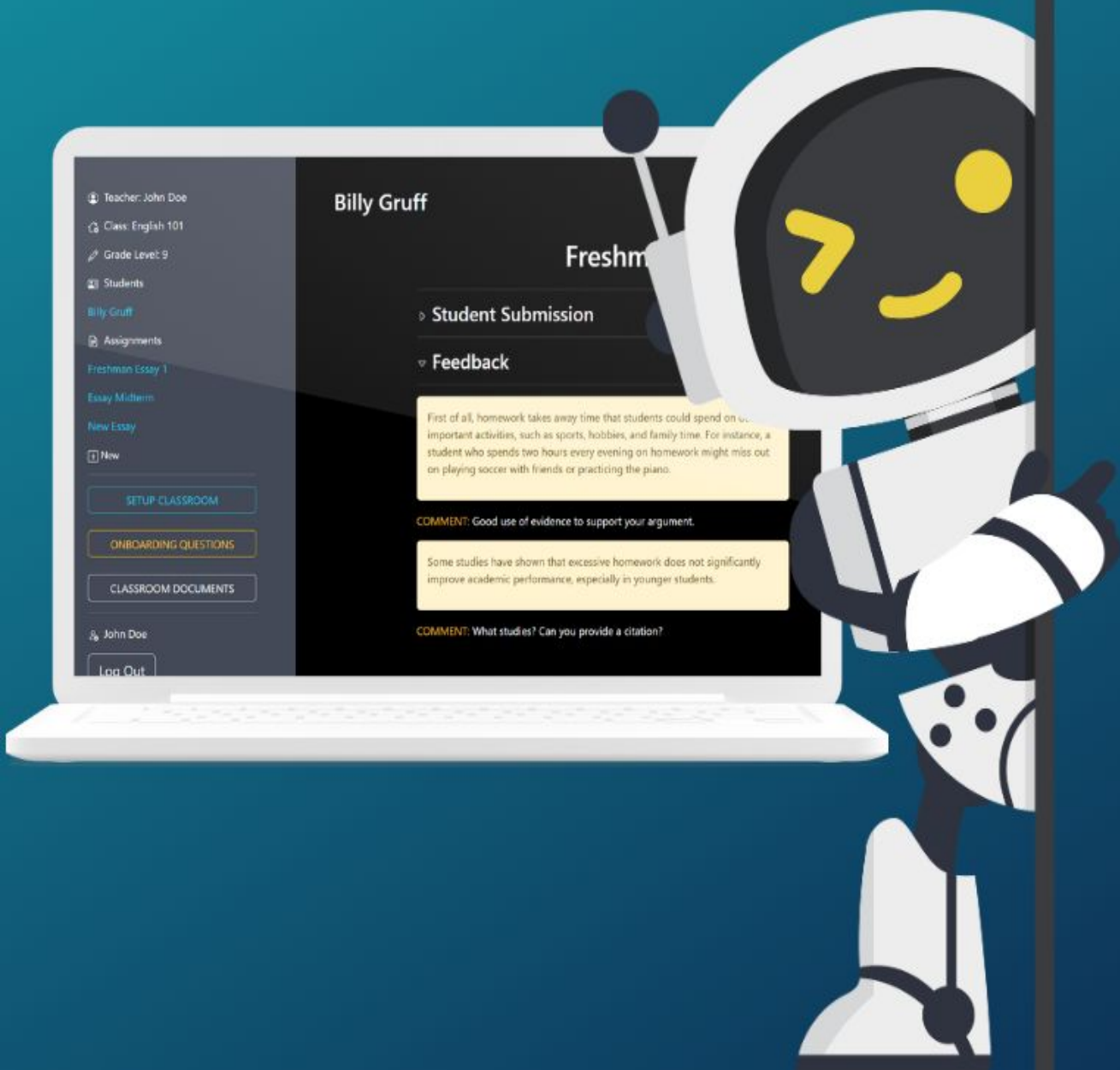

Thanks!

Any questions?

richard.mathews@berkeley.edu
daphnelin@berkeley.edu
snaser1@berkeley.edu
emcpherson@berkeley.edu
patrick.xu@berkeley.edu